



DA-SNAP

Wall-Mounted Projection Screen

SPECIFICATION DATA

DA-LITE SCREEN COMPANY, INC.
3100 North Detroit Street
Post Office Box 137
Warsaw, Indiana 46581-0137
Phone: 574-267-8101
800-622-3737
Fax: 574-267-7804
Toll Free Fax: 877-325-4832
www.da-lite.com
e-mail: info@da-lite.com

SUGGESTED SPECIFICATIONS: _____ fixed wall projection screen(s), _____ (H) x _____ (W). To have flexible screen surface, fire retardant and mildew resistant. Screen surface standard with reinforced black binding on all four sides and will attach to frame with metal snaps. Frame will conceal snaps and binding. Screen frame will be 1½" square matte black powder coated aluminum. Walls will be ribbed for strength and light weight. Frame will be slip-jointed at corners and joints. Standard wall-mounting brackets will be included.

All Da-Mat®, High Contrast Da-Mat®, Cinema Vision, High Contrast Cinema Vision, Pearlescent, Da-Tex® and Dual Vision surfaces are seamless up to 16' high.

Audio Vision, High Contrast Audio Vision and High Contrast Cinema Perf surfaces are available in sizes up to 8' high.

High Power® surface is available in sizes up to 6' high.

All viewing surfaces are standard with black backing except Da-Tex® and Dual Vision.

WHEN ORDERING, MARK APPROPRIATE SELECTIONS:

Select size from chart on reverse side.

Select viewing surface:

- Da-Mat®
- High Contrast Da-Mat®
- Cinema Vision
- High Contrast Cinema Vision
- High Contrast Cinema Perf
- Pearlescent
- High Power®
- Audio Vision
- High Contrast Audio Vision
- Da-Tex® (Rear)
- Dual Vision

Greenguard® and Greenguard® Children and Schools Certified.

Options:

- T-Legs (must be ordered at the same time as screen).
- Velcro® Attachment (snaps standard).
- Wrap-Around fabric.
- Pro-Trim®: Pro-Trim® is a fabric covering that aesthetically enhances the appearance of the installation. Pro-Trim® provides a stylish masked border while absorbing the light that surrounds the viewing area.
- Pro Imager Masking System (Refer to the Pro Imager specification data sheet for size availability and more details).

Project:	_____
Architect:	_____
Phone:	_____
Contractor:	_____
Phone:	_____
Supervisor:	_____
Phone:	_____
Date:	_____
Revised:	_____

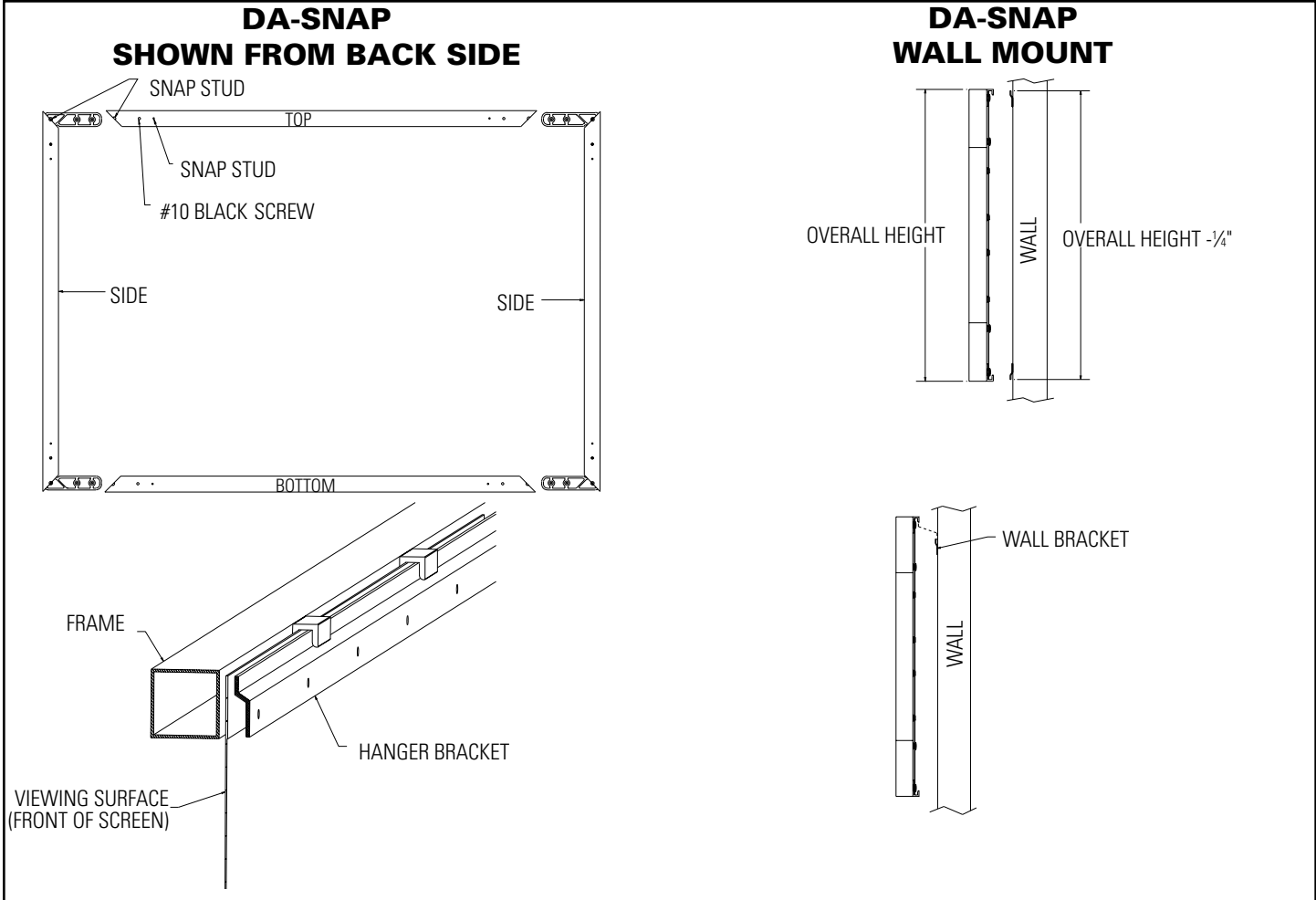

VIDEO (NTSC 4:3) FORMAT DIMENSIONS

Viewing Area		Nominal Diagonal		Overall Dimensions		Approx. Ship. Wt.	
H x W	Cm	In.	Cm	In.	Cm	Lbs.	Kg
36" x 48"	91 x 122	60"	152	39" x 51"	99 x 130	20	9.1
43" x 57½"	109 x 146	72"	183	46" x 60½"	117 x 154	23	10.4
50½" x 67"	128 x 170	84"	213	53½" x 70"	136 x 178	26	11.8
57½" x 77"	146 x 196	96"	244	60½" x 80"	154 x 203	28	12.7
60" x 80"	152 x 203	100"	254	63" x 83"	160 x 211	31	14.1
72" x 96"	183 x 244	120"	305	75" x 99"	191 x 251	38	17.2
90" x 120"	229 x 305	150"	381	93" x 123"	236 x 312	48	21.8
108" x 144"	274 x 366	180"	457	111" x 147"	282 x 373	63	28.6
120" x 160"	305 x 406	200"	508	123" x 163"	312 x 414	75	34.0
144" x 192"	366 x 488	240"	610	147" x 195"	373 x 495	90	40.8

HDTV (16:9) FORMAT DIMENSIONS

Viewing Area		Nominal Diagonal		Overall Dimensions		Approx. Ship. Wt.	
H x W	Cm	In.	Cm	In.	Cm	Lbs.	Kg
37½" x 67"	95 x 170	77"	196	40½" x 70"	103 x 178	24	10.9
40½" x 72"	103 x 183	82"	208	43½" x 75"	110 x 191	26	11.8
45" x 80"	114 x 203	92"	234	48" x 83"	122 x 211	28	12.7
49" x 87"	124 x 221	100"	254	52" x 90"	132 x 229	30	13.6
52" x 92"	132 x 234	106"	269	55" x 95"	140 x 241	32	14.5
54" x 96"	137 x 244	110"	279	57" x 99"	145 x 251	33	15.0
58" x 104"	147 x 264	119"	302	61" x 107"	155 x 272	36	16.3
65" x 116"	165 x 295	133"	338	68" x 119"	172 x 302	37	16.8
78" x 139"	198 x 353	159"	404	81" x 142"	206 x 361	50	20.9
94½" x 168"	240 x 427	193"	490	97½" x 171"	248 x 434	75	34.0
108" x 192"	274 x 488	220"	559	111" x 195"	282 x 495	90	40.8

16:10 WIDE FORMAT DIMENSIONS

Viewing Area		Nominal Diagonal		Overall Dimensions		Approx. Ship. Wt.	
H x W	Cm	In.	Cm	In.	Cm	Lbs.	Kg
50" x 80"	127 x 203	94"	239	53" x 83"	135 x 211	28	12.7
60" x 96"	152 x 244	113"	287	63" x 99"	160 x 251	33	15
69" x 110"	175 x 279	130"	330	72" x 113"	183 x 287	37	16.8
87" x 139"	221 x 353	164"	417	90" x 142"	229 x 361	50	22.7

CINEMASCOPE FORMAT DIMENSIONS

Viewing Area		Nominal Diagonal		Overall Dimensions		Approx. Ship. Wt.	
H x W	Cm	In.	Cm	In.	Cm	Lbs.	Kg
37½" x 88"	95 x 224	96"	244	40½" x 91"	103 x 231	30	13.6
40½" x 95"	103 x 241	103"	262	43½" x 98"	110 x 249	33	15.0
45" x 106"	114 x 269	115"	292	48" x 109"	122 x 277	36	16.3
49" x 115"	124 x 292	125"	318	52" x 118"	132 x 300	37	16.8
52" x 122"	132 x 310	133"	338	55" x 125"	140 x 318	42	19.1
54" x 126"	137 x 320	138"	351	57" x 129"	145 x 328	47	21.3
58" x 136½"	147 x 347	148"	376	61" x 139½"	155 x 354	49	22.2
65" x 153"	165 x 389	166"	422	68" x 156"	173 x 396	56	25.4
78" x 183½"	198 x 466	199"	505	81" x 186½"	206 x 474	85	38.5
81½" x 192"	207 x 488	208"	528	84½" x 195"	215 x 495	90	40.8

Overall dimensions ±¼" (6mm).
 Specifications subject to change without notice.
 Custom formats and sizes available upon request.