

TENSIONED DUAL MASKING ELECTROL®

Concealed without Doors Masking Electric Projection Screen

When ordering, make appropriate selections:

- Select size from charts at the lower right.
- Select viewing surface:
  - Da-Mat
  - High Contrast Da-Mat
  - Cinema Vision
  - High Contrast Cinema Vision
  - Pearlescent
  - Audio Vision
  - High Contrast Audio Vision
  - High Contrast Cinema Perf
  - Da-Text (Rear)
  - Dual Vision
  - GREENGUARD® and GREENGUARD® Children and Schools Certified.
- Options:
  - Dual Motor Low Voltage Control System (DMC).
  - Wireless Remote Control for DMC.
    - Radio Frequency Remote.
    - Radio Frequency Range Extender available
    - Infrared Remote.
  - 220 Volt (50Hz) Motor.
  - White box (black standard).
  - Silent Motor.



- Dual-motor electric screen.
- View from Letterbox to NTSC format or from HDTV to NTSC format.
- Tab guide cable system holds screen surface flat.

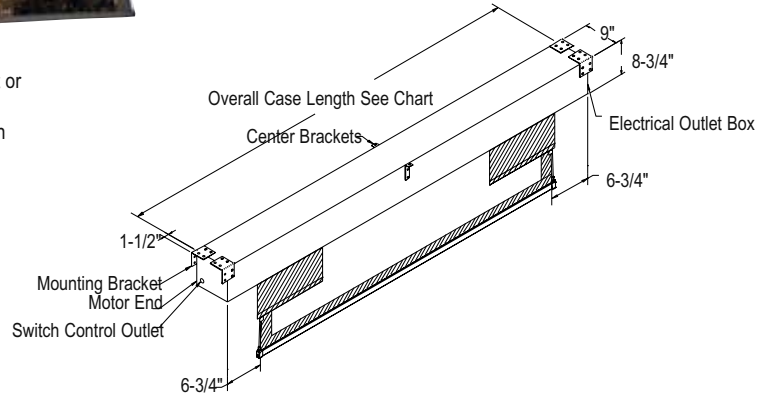

SUGGESTED SPECIFICATIONS:

\_\_\_\_\_ projection screen(s), \_\_\_\_\_ (H) x \_\_\_\_\_ (W), electrically operated 120 volt (60 Hz) not more than 4.8 amp. Shall have two specially designed motors mounted inside two rollers, to be three wire with ground quick reversal type, oiled for life, with automatic thermal overload cutout, integral gears, capacitor and an electric brake to prevent coasting. To have pre-set limit switches to automatically stop picture surfaces in the "up" and "down" positions. The fabric roller to be of rigid aluminum. The mask roller to be of rigid metal. Screen fabric to be seamless, flame retardant and mildew resistant vinyl with black masking borders standard. Each side of the fabric to have tab guide cable system to maintain even lateral tension and hold surface flat. To have masking fabric on sides to convert the screen to different aspect ratios. Bottom of fabric to be inserted into an aluminum slat bar with added weight to maintain vertical tension on the screen surface. The ends of the slat to be protected by heavy duty plastic caps enclosing a preset adjustable mechanism for screen tensioning. Bottom of each masking fabric shall be formed into a pocket holding a flat steel bar. Case to be of wood and be finished with a black primer coat, ready to accept final finish by others. To be complete with a three position control switch and a two position control switch in a two gang box with cover plate. Screen to be listed by Underwriters' Laboratories.



All viewing surfaces will be seamless. Audio Vision, High Contrast Audio Vision and High Contrast Cinema Perf available in sizes up to 87" x 155" in HDTV Format and 87" x 161" in Letterbox Format. All viewing surfaces are standard with black backing except Da-Text® and Dual Vision.

Detailed dimensional drawings, wiring diagrams and installation instructions available upon request. Specifications subject to change without notice.

HDTV (1.78:1) TO VIDEO (1.33:1) FORMAT DIMENSIONS

HDTV H x W	HDTV Nominal Diagonal	NTSC Video H x W	Video Nominal Diagonal	Overall Case Length*	Approx. Shipping Wt. Lbs.
45" x 80"	92"	45" x 60"	75"	103 1/4"	117
50" x 89"	102"	50" x 67"	84"	112 3/4"	123
54" x 96"	110"	54" x 72"	90"	120 1/4"	132
60" x 107"	122"	60" x 80"	100"	131 3/4"	145
69" x 123"	141"	69" x 92"	120"	149 3/4"	163
87" x 155"	177"	87" x 116"	150"	184 3/4"	186

LETTERBOX (1.85:1) TO VIDEO (1.33:1) FORMAT DIMENSIONS

Letterbox H x W	Letterbox Nominal Diagonal	NTSC Video H x W	Video Nominal Diagonal	Overall Case Length*	Approx. Shipping Wt. Lbs.
50" x 92 1/2"	105"	50" x 67"	84"	116 1/4"	117
60" x 111"	126"	60" x 80"	100"	135 3/4"	140
69" x 128"	145"	69" x 92"	120"	154 3/4"	157
87" x 161"	183"	87" x 116"	150"	190 3/4"	180

CINEMASCOPE (2.35:1) TO HDTV (1.78:1) FORMAT DIMENSIONS

Cinemascope H x W	Cinemascope Nominal Diagonal	HDTV H x W	HDTV Nominal Diagonal	Overall Case Length*	Approx. Shipping Wt. Lbs.
45" x 106"	115"	45" x 80"	92"	129 1/4"	145
49" x 115"	125"	49" x 87"	100"	138 3/4"	155
52" x 122"	133"	52" x 92"	106"	146 1/4"	161
54" x 126"	138"	54" x 96"	110"	150 1/4"	168
58" x 136"	148"	58" x 104"	119"	160 3/4"	175
65" x 153"	166"	65" x 116"	133"	178 3/4"	189

Overall case length dimensions ± 1/4".

\*Add 3" to overall length of case for mounting brackets.

Note: All screen sizes listed are viewing areas. Custom sizes available upon request. All sizes come standard with 12" black drop at top.