

ASCENDER® ELECTROL®

Concealed or Surface Floor Mounted Electric Projection Screen

When ordering, make appropriate selections:

1. Select size from charts at the lower right.
2. Select viewing surface:
  - Matte White
  - Video Spectra 1.5
  - High Power
  - GREENGUARD® and GREENGUARD® Children and Schools Certified.
3. Options:
  - No borders (Black masking borders standard).
  - Wireless Remote Control.
    - Radio Frequency Remote
    - Radio Frequency Range Extender available
  - Infrared Remote
  - Key Locking Cover Plate for LVC Switch.
  - 220 Volt (50 Hz) Motor.
  - White box and door (black standard).



Figure 1

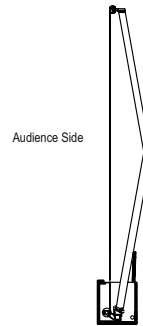
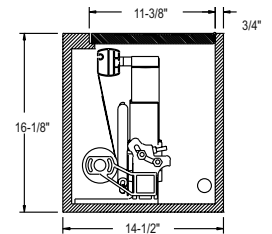

Figure 2



- Patented in-the-roller mounting system for quiet operation.
- Motorized spring assisted scissor mechanism ensures smooth performance.
- Trap door hides the screen and mechanism until needed.
- Engineered safety feature will not allow the screen surface to rise if the door is obstructed.

SUGGESTED SPECIFICATIONS:

\_\_\_\_\_ projection screen(s),  
 \_\_\_\_\_ (H) x \_\_\_\_\_ (W),  
 electrically operated 120 volt (60 Hz) not more than 2.4 amp. Fabric to be flame retardant and mildew resistant fiberglass with black masking borders standard. To be mounted on rigid steel roller. Screen to be raised vertically by two spring loaded aluminum arms. Shall have specially designed motor mounted inside the roller, to be three wire with ground, quick reversal type, oiled for life, with automatic thermal overload cutout, integral gears, capacitor and an electric brake to prevent coasting. To have preset but adjustable limit switches to automatically stop picture surface in the "up" and "down" position. Case to be made of 3/4" wood and finished with a black primer coat, ready to accept final finish by others. Top of case and lid to be covered with black laminate. Safety features to include a lid switch to reverse and stop the screen from rising if the lid does not open. Screen to be operated by low voltage control unit, momentary contact rocker switch, and inputs for optional infrared or radio frequency remote control. To be listed by Underwriters' Laboratories.



**Matte White:** Seamless in all standard sizes.  
**Video Spectra 1.5:** Available in sizes where both dimensions do not exceed 8'.  
**High Power:** Available in sizes up to 9'x12'.  
 Horizontal seam required when both dimensions exceed 6'.

Detailed dimensional drawings, wiring diagrams and installation instructions available upon request. Specifications subject to change without notice.

Front View

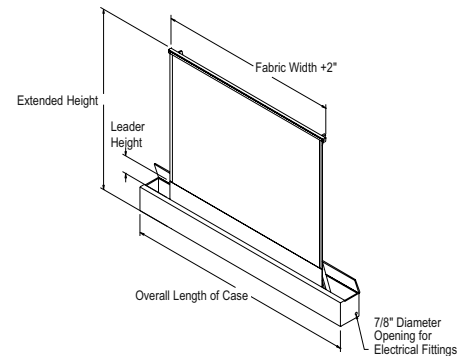

Back View

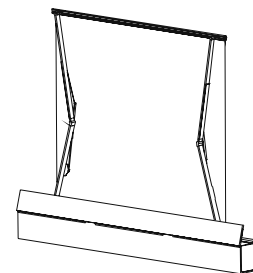

4:3 VIDEO FORMAT DIMENSIONS

Viewing Area H x W	Nominal Diagonal	Overall Case Length	Extended Height	Leader Height	Approx. Shipping Wt. Lbs.
60" x 80"	100"	130"	94"	15"	485
69" x 92"	120"	130"	100"	12"	490
87" x 116"	150"	158"	117"	11"	585
105" x 140"	180"	178"	139"	15"	654
120" x 160"	200"	178"	146"	6"	660

16:9 HDTV FORMAT DIMENSIONS

Viewing Area H x W	Nominal Diagonal	Overall Case Length	Extended Height	Leader Height	Approx. Shipping Wt. Lbs.
52" x 92"	106"	130"	86"	15"	480
58" x 104"	119"	130"	92"	15"	485
65" x 116"	133"	134"	99"	15"	500
78" x 139"	159"	158"	112"	15"	600

Overall case length dimensions ±1/4".  
 12" clearance required from back of screen housing for clearance of extension arms.