

FRAMING: DELUXE AND SELF-TRIMMING

Frame Cross Section And Size Selection Information:

Da-Lite's Polacoat®, Da-Plex, Da-Glas And Da-View Screens

Factory Framed Screens:

- For installation ease, rear projection screens are available in factory frames.
- All frames are of 6063-T5 aluminum alloy with 204-A1R1 black anodized finish.
- Framed screens are shipped as a complete assembly.
- Easily installed in finished openings by carpenters, framed screens eliminate on-site glazing costs.

To Install:

1. Set screen in opening.
2. Trim out with decor matched moldings. Note: Self-Trimming Frame requires no trim-out.
3. Shim when necessary.

Select the Frame:

Deluxe Frame

- Impressive architectural design adds sophistication to every installation.
- Heavy-duty box frame construction of 2³/₄" x 3" (69.85 mm x 76 mm) rectangular dovetailed tube of .125" (3.18 mm) wall thickness is secured at the corners with self-tapping screws and mounting clips of .125" aluminum channel.
- Dovetailed design eliminates light leaks without caulking.
- Ideal for larger, heavier glass or acrylic screens in 1/2" thickness up to 10' x 20' glass and 9' x 18' acrylic.
- Available in an anodized black finish.
- Frame dimension equals viewing area plus 5¹/₂".

Self-Trimming Frame

- Self-Trimming feature eliminates the need for finish trim and makes for a fast and easy installation.
- Built-in 1¹/₂" wide finished molding to hide opening.
- Recommended for use with 1/4", 3/8" and 1/2" Da-Plex and Da-Glas in sizes up to 20' wide.
- Consult factory for larger sizes.
- Available in an anodized black finish.
- Adds 5⁷/₈" to overall viewing area.
- Frame insert size equals viewing area plus 2⁷/₈".

Specify the Size of Framed Screens:

The customer must specify overall size of the frame outside dimension (not size of opening) and must be careful to allow for the space required to fit the factory framed screen into the opening. Note: The Self-Trimming Frame's finish molding is part of the frame. Be sure to use the measurement from the edge of the frame not the edge of the finish molding when calculating the frame insert size.

Framing Detail Factory-Installed Frame:

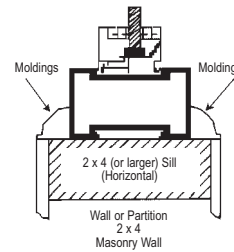

Framed Da-Lite, Da-Plex, Da-Glas and Da-View in-wall rear projection screens should be mounted in a vertical position, resting on the bottom of the frame on a suitably reinforced surface in an aperture, in a wall or partition. The unit should be shimmed and fixed in position with appropriate moldings to lock the framed panel in position.

Deluxe Frame

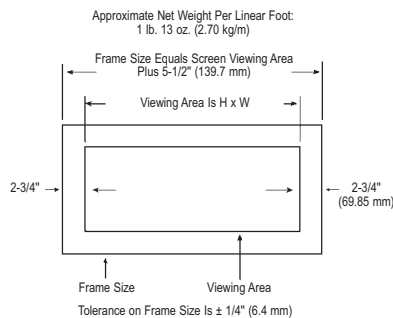
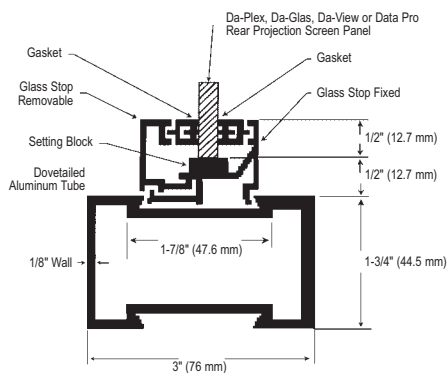

Self-Trimming Frame

