

## Mobile Plasma Stand Cabinet MPS-C

Form E-450  
 Rev. 11 / 08

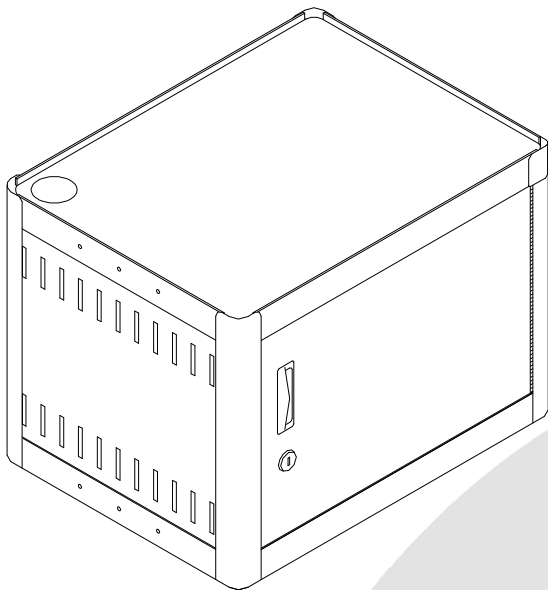

**Caution:** This product is designed for installation on a Mobile Plasma Stand only. Qualified personnel using appropriate fasteners should mount the Cabinet to the Mobile Plasma Stand.

### Required Tools:

- 7/16" wrench
- 5/16" hex driver
- Drill motor

### Procedure

1. Remove contents from carton and examine for damaged or missing parts.

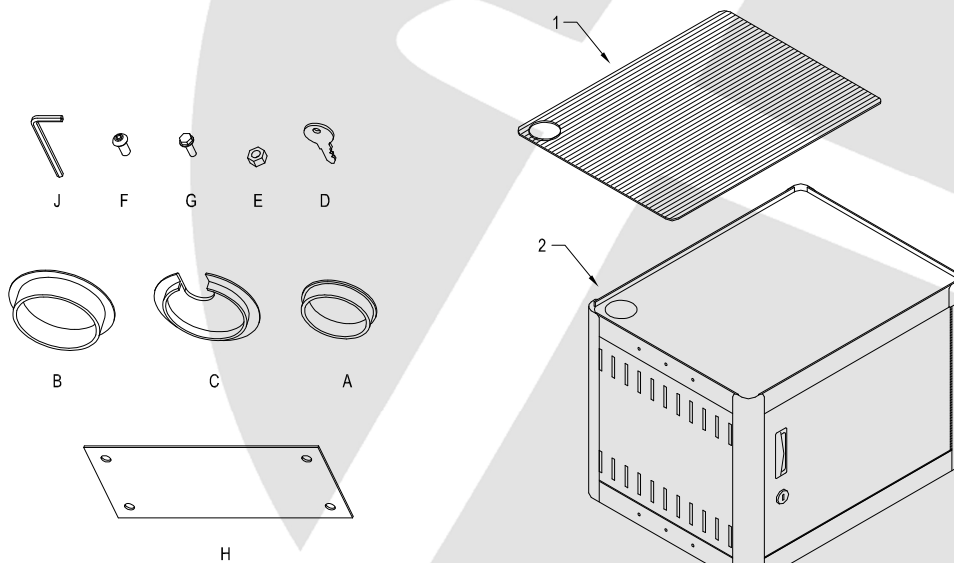

ITEM	DESCRIPTION	QTY
1	MAT	1
2	CABINET ASSEMBLY	1
	PACKAGE SET	1
A	GROMMET, 2"	1
B	GROMMET, 2-1/2"	1
C	GROMMET COVER, 2-1/2"	1
D	KEY	2
E	NUT, HEX 1/4"-20 KEPS	4
F	SCREW, BHSCS 1/4"-20 X 1/2"	4
G	SCREW, SELF DRILLING #10	4
H	ATTACHING PLATE	2
J	WRENCH, ALLEN 5/32"	1

2. Place Cabinet onto Base of Mobile Plasma Stand. See Figure 1.
3. Fasten Attaching Plates to both sides of the Cabinet.
4. Fasten the Attaching Plates to the Mobile Plasma Stand with self-drilling screws.

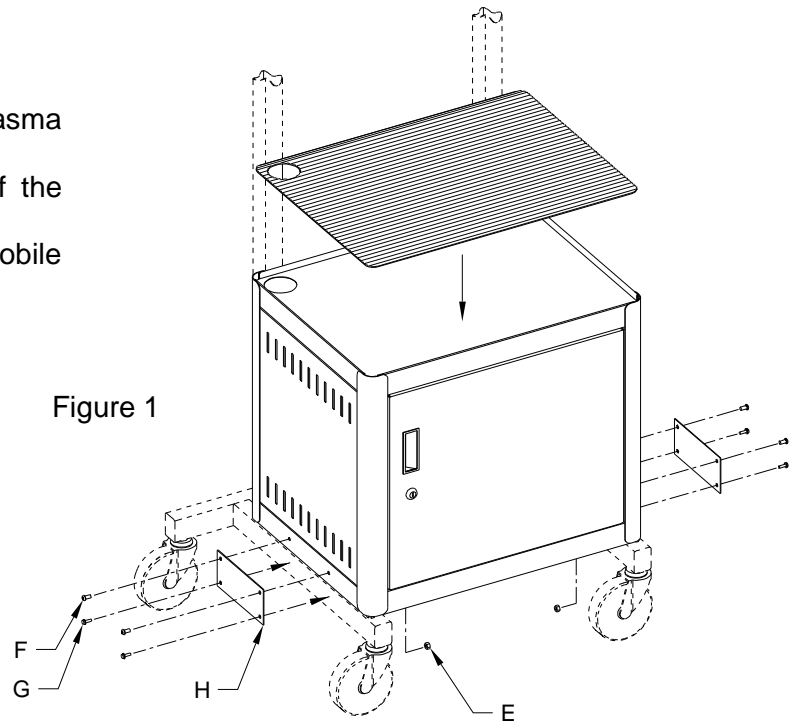

5. Place Rubber Mat on top of Cabinet. See Figure 2.
6. Install Grommets and Grommet Cover.

