

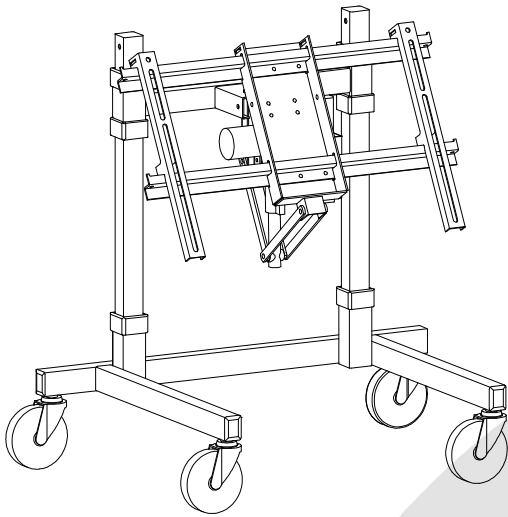

DA-LITE SCREEN COMPANY, INC.
3100 North Detroit Street
Post Office Box 137
Warsaw, IN 46581-0137
Phone: 574.267.8101
Toll Free: 800.622.3737
Fax: 574.267.7804
www.da-lite.com
info@da-lite.com

Automated Confidence Monitor Stand MPS-ACM

Form E-443
Rev. 11 / 08



Caution: The user of this product should exercise caution when moving the Automated Confidence Monitor Stand. Any sudden stop could cause instability of the stand and could cause serious injury and/or damage. The stand should always be pushed, never pulled, by the user. Always push from the side of the stand, never from the front or back of the stand.

IMPORTANT SAFETY INSTRUCTIONS

When using your video equipment, basic safety precautions should always be followed, including the following:

1. Read and understand all instructions before using.
2. Position the cord so that it will not be tripped over, pulled, or contact hot surfaces.
3. If an extension cord is necessary, a cord with a current rating at least equal to that of the appliance should be used. Cords rated for less amperage than the appliance may overheat.
4. To reduce the risk of electric shock, do not disassemble this appliance. Contact an authorized service dealer when repair work is required. Incorrect reassembly can cause electric shock when the appliance is used subsequently.
5. The use of an accessory attachment not recommended by the manufacturer may cause a risk of fire, electric shock, or injury to persons.

SAVE THESE INSTRUCTIONS

Procedure

1. Remove contents from carton and examine for damaged or missing parts.

Required Tools:

- 7/16" wrench
- 9/16" wrench
- 3/16" allen wrench
- Phillips screwdriver

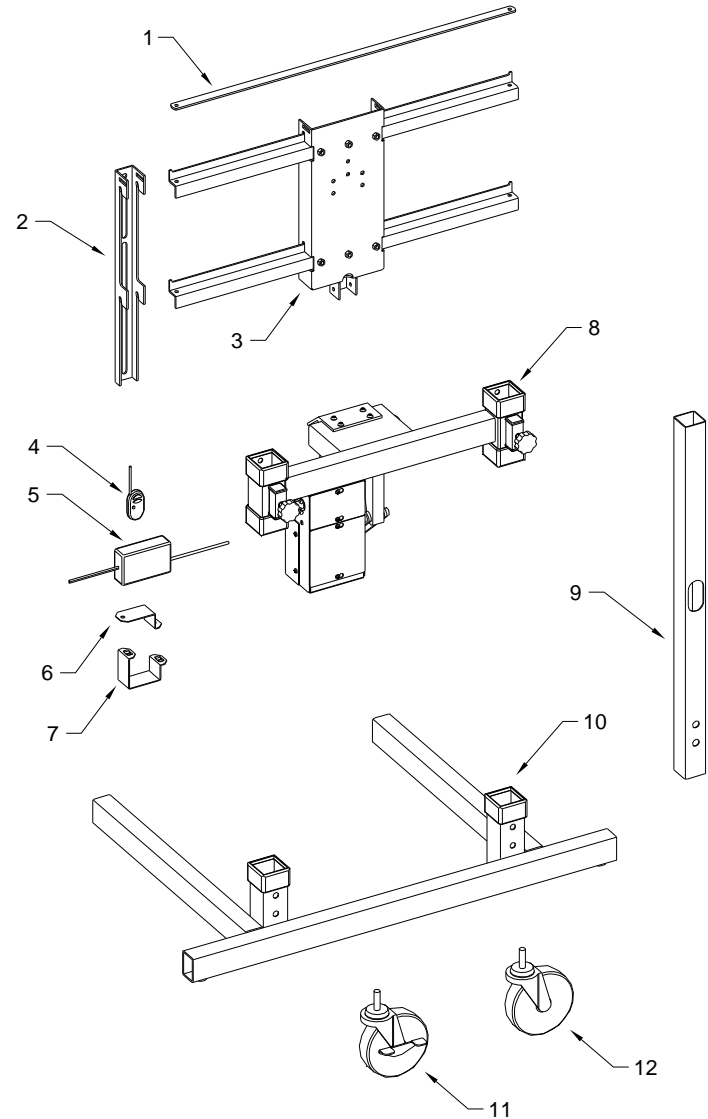
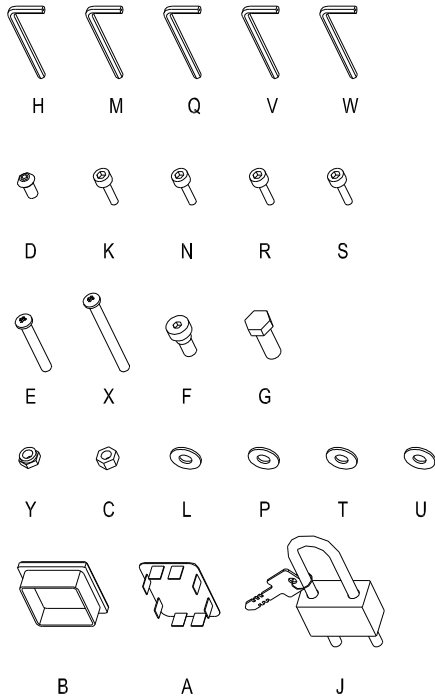

ITEM	DESCRIPTION	QTY
1	SECURITY BAR	1
2	HANGING BRACKET	2
3	ZEE-BAR PLATE ASS'Y	1
4	KEY FOB REMOTE, RF	1
5	POWER SUPPLY	1
6	POWER SUPPLY BRACKET, SMALL	1
7	POWER SUPPLY BRACKET, LARGE	1
8	TOP ASSEMBLY	1
9	COLUMN	2
10	BASE ASSEMBLY	1
11	CASTER, 5" W/ BRAKE	2
12	CASTER, 5"	2
	PACKAGE SET	1
A	END CLOSURE, 1-1/2" X 2"	4
B	END CLOSURE, 1-3/4" SQUARE	2
C	NUT, HEX 1/4"-20 KEPS	4
D	SCREW, BHSCS 1/4"-20 X 1/2"	6
E	SCREW, MACH 1/4"-20 X 2"	2
F	SCREW, SHOULDER 3/8 X 3/8"	2
G	SCREW, HHCS 3/8"-16 X 1"	4
H	WRENCH, ALLEN 5/32"	1
	PACKAGE SET	1
J	PADLOCK W/ KEYS	1
	PACKAGE SET	1
K	SCREW, SHCS M8 X 20mm	4
L	WASHER, FLAT 3/8"	4
M	WRENCH, ALLEN 6mm	1
	PACKAGE SET	1
N	SCREW, SHCS M6 X 20mm	4
P	WASHER, FLAT 1/4"	4
Q	WRENCH, ALLEN 5mm	1
	PACKAGE SET	1
R	SCREW, SHCS M5 X 20mm	4
S	SCREW, SHCS M4 X 12mm	4
T	WASHER, FLAT #10	4
U	WASHER, FLAT #8	4
V	WRENCH, ALLEN 4mm	1
W	WRENCH, ALLEN 3mm	1
	PACKAGE SET	1
X	SCREW, MACH 1/4"-20 X 2-1/2"	1
Y	NUT, HEX 1/4"-20 NYLON LOCK	1
C	NUT, HEX 1/4"-20 KEPS	1

2. Insert the Caster stems into the Base. See Figure 1. Must go in straight.
3. Insert tube enclosures shown in Figure 1.
4. Insert two Columns into the Base and install the fasteners shown. See Figure 1. Leave loose at this time.

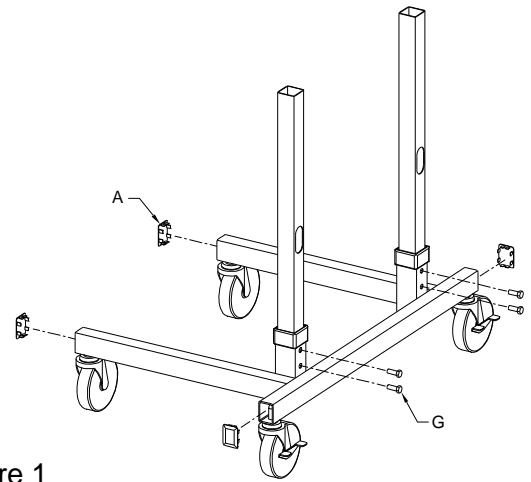

Figure 1

5. Slide the Top Assembly down the Columns. See Figure 2. Position the Top by tightening both Knobs. Make sure unit is level.
6. Tighten the fasteners at the bottom of the Columns.

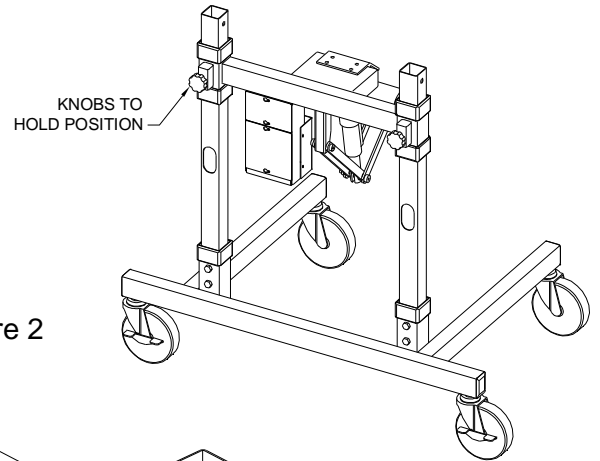

Figure 2

7. Attach Zee-Bar Plate to Hinge. See Figure 3.
8. Attach the Links to the outside of the Zee Bar Assembly.

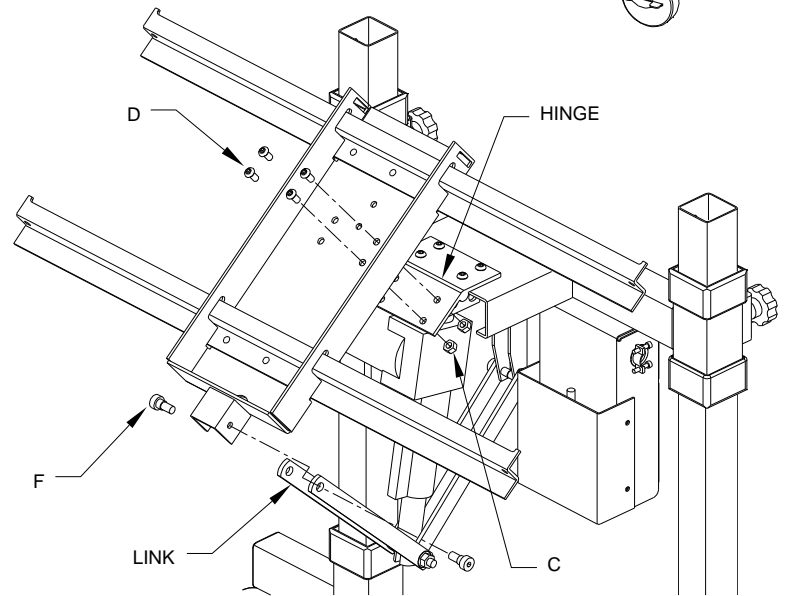

Figure 3

9. Mount the Hanging Brackets to the back of the Plasma Unit utilizing all the fastener points recommended by the plasma manufacturer. See Figure 4.

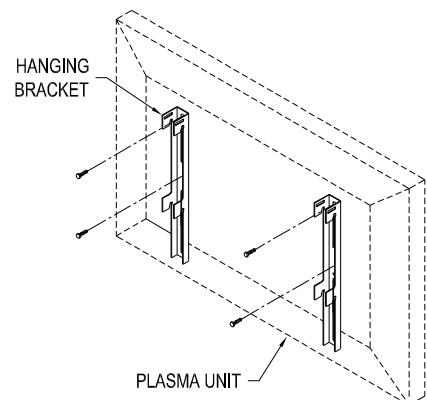

Figure 4

10. Hang the plasma unit on the Zee-Bars making sure the top and bottom notches on each Hanging Bracket are placed over the upper and lower Zee-Bars. See Figure 5.
11. Slide the Security Bar through the slots in the Hanging Brackets, bolt one end to the Zee-Bar then secure the opposite end with the pad lock. See Figure 5 & 6.

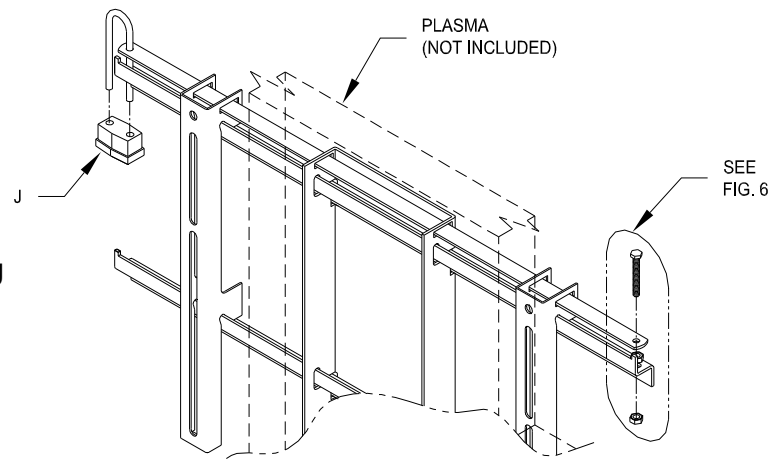

Figure 5

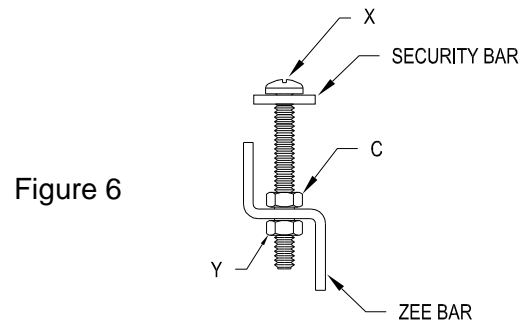

Figure 6

12. Install Power Supply. See Figure 7.
13. Plug electrical cord into power supply.
14. Connect power plug into receiver electrical housing.
15. Remote control is included in power supply carton. The small red button on the remote is for "stop" but is not needed. The confidence monitor will stop with the release of either the "up" or "down" button. See Figure 8.



Figure 8

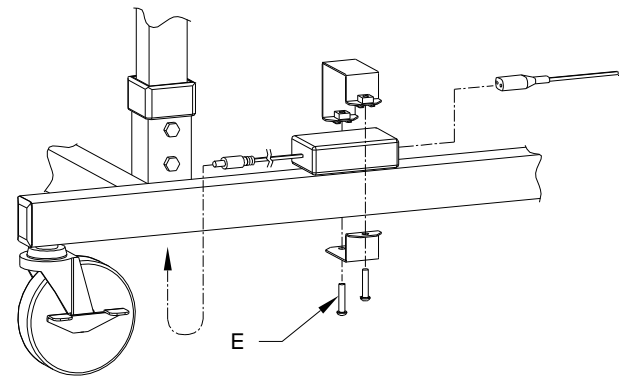

Figure 7

16. Install tube enclosures. See Figure 9.
17. Install fasteners into top of Columns for theft deterrent.

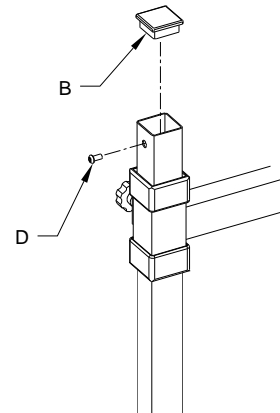

Figure 9