

The Da-Lite Difference.



**Instruction Book for
TENSIONED CONTOUR® ELECTROL®**



DA-LITE SCREEN COMPANY, INC.

3100 North Detroit Street
Post Office Box 137
Warsaw, Indiana 46581-0137
Phone: 574-267-8101
800-622-3737
Fax: 574-267-7804
Toll Free Fax: 877-325-4832
www.da-lite.com
e-mail: info@da-lite.com

IMPORTANT SAFETY INSTRUCTIONS

When using your video equipment, basic safety precautions should always be followed, including the following:

1. Read and understand all instructions before using.
2. Position the cord so that it will not be tripped over, pulled, or contact hot surfaces.
3. If an extension cord is necessary, a cord with a current rating at least equal to that of the appliance should be used. Cords rated for less amperage than the appliance may overheat.
4. To reduce the risk of electric shock, do not disassemble this appliance. Contact an authorized service dealer when repair work is required. Incorrect reassembly can cause electric shock when the appliance is used subsequently.
5. The use of an accessory attachment not recommended by the manufacturer may cause a risk of fire, electric shock, or injury to persons.

SAVE THESE INSTRUCTIONS

INSTALLATION

Carefully unpack screen and remove outer wrapping from case.

Remove the shipping braces from the slat bar before the case is installed.

There are three ways to install the Tensioned Contour® Electro®: Wall Mount, Ceiling Mount, or Ceiling Hook. Procedures for each method are as follows:

Wall Mount

1. Secure the wall mount bracket to the wall at the desired height. Bracket should be fastened to wall studs or some reinforcement within the wall. Concrete or brick walls require special fasteners and anchors.
2. Make sure the bracket is level. See figure 1 for reference dimensions.
3. Keep in mind you will need at least 2-3/8" between the ceiling and the top of the wall mount bracket to be able to position the case on the bracket.
4. Mount the screen case on the wall bracket as shown in figure 1. Be sure the case is fully seated on the bracket. Tighten the stop screws against the wall bracket.

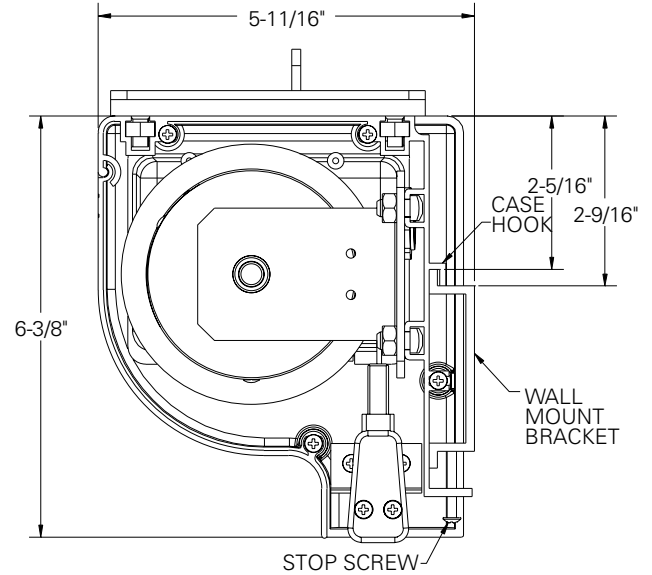

FIGURE 1

Ceiling Mount

1. Do not remove the wall mount bracket, even if you are not using it for mounting. This provides structural stability to the case.
2. Be sure the ceiling has adequate reinforcement to attach the screen brackets.
3. The top of the screen case has two channels with threaded nuts that slide the length of the case. Attach two ceiling mount brackets to the screen case as shown in figure 2. Mount cannot be more than 12" from end of case.
4. Hold the screen case up to the ceiling and mark the hole locations. The brackets have a set of front holes and a set of rear holes. It is best to use at least one hole in each set.

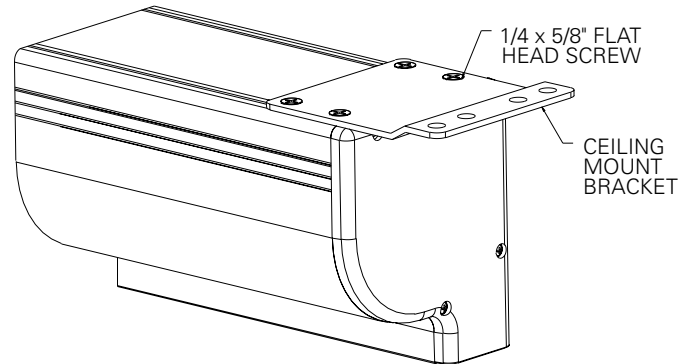

FIGURE 2

Ceiling Hook

1. Do not remove the wall mount bracket, even if you are not using it for mounting. This provides structural stability to the case.
2. Be sure the ceiling has adequate reinforcement to attach a hook anchor.
3. The top of the screen case has two channels with threaded nuts that slide the length of the case. Attach ceiling hook brackets as provided to the screen case as shown in figure 3.
4. The brackets can be attached anywhere within 12" of the end of the case.
5. Attach an S-hook or similar fastener to the hole in the bracket.

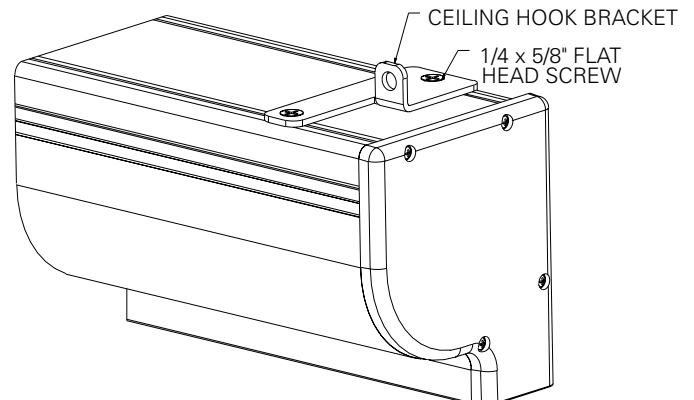

FIGURE 3

ELECTRICAL INSTALLATION

Internal wiring has been completed at the factory. Installer must route power to the wall switch and to the junction box located on the left end of the screen case.

Standard installation is for a single 120VAC or 240VAC wall switch to control the screen. Optional Control units may have been ordered. Wiring diagrams for the built-in VPI and low voltage control are included in these instructions. Refer to additional instructions for the external VPI, external low voltage control, SCB-100 and SCB-200. Refer to the appropriate wiring diagram for your screen.

Test installation by running screen up and down a few times. Be prepared to stop screen.

Standard Duty Cycle: 1MIN. ON / 3 MIN. OFF.

NOTE: Must be installed in accordance with the requirements of the Local Building Codes, the Canadian Electrical Code (CEC), CAN/CSA C22.1 and the National Electric Code (NEC), NFPA 70.

SCREEN ADJUSTMENT

Screen travel is stopped automatically in the down and up positions by the limit switches that are preset at the factory. If it's necessary to adjust for more or less drop follow the steps below.

 **CAUTION: Do not adjust for more drop than what was ordered. At least 1-1/2 wraps of fabric must remain on the roller. This screen comes standard with 12" black at the top.**

 **CONTACT DA-LITE AT 800-622-3737 OR 574-267-8101 IF SCREEN MOTOR NEEDS ADJUSTMENT.**

TENSIONED CONTOUR® ELECTROL® INSTALLATION

120V WIRING DIAGRAM FOR STANDARD WALL SWITCH

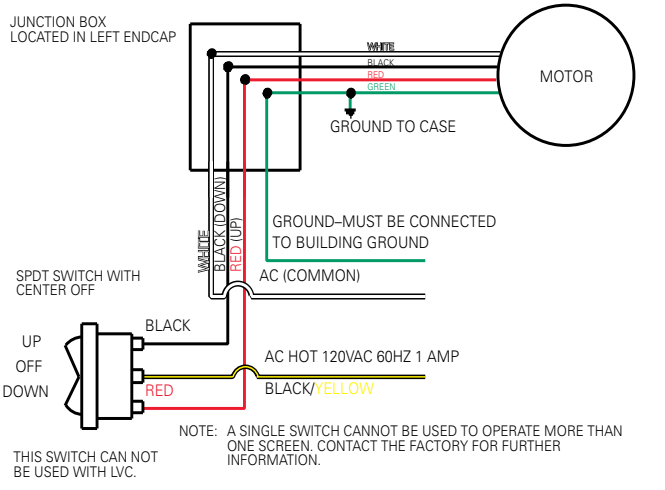

240 VOLT WIRING DIAGRAM FOR STANDARD WALL SWITCH:

Da-Lite offers two styles of 240 volt wall switches for standard operation. Please see wiring diagram included in wall switch box included with screen.

120V WIRING DIAGRAM WITH OPTIONAL BUILT-IN VIDEO PROJECTOR INTERFACE

CAUTION: THE PROJECTOR MUST BE TURNED OFF BEFORE CONNECTING THE TRIGGER WIRES TO THE PROJECTOR. FAILURE TO DO SO MAY DAMAGE THE CONTROLLER.

Use 2-conductor 20-24 gauge wire to extend the low voltage connection from the projector's 5 or 12-volt screen trigger output to the length required to reach the VPI. When extending the low voltage connection from the projector's screen trigger output polarity does not matter. The red and black wires from the VPI are interchangeable.

IMPORTANT NOTE:

The wall switch is REQUIRED to make any limit switch adjustments, EVEN if a third party control system is used. Therefore, it is advised to wire the switch or provide a 3-conductor connection that is accessible.

3-conductor 20-24 gauge wire can be used in place of the supplied RJ-14 cable to connect the wall switch. Connect the BUS terminals on the wall switch to the corresponding BUS terminals on the splitter board.

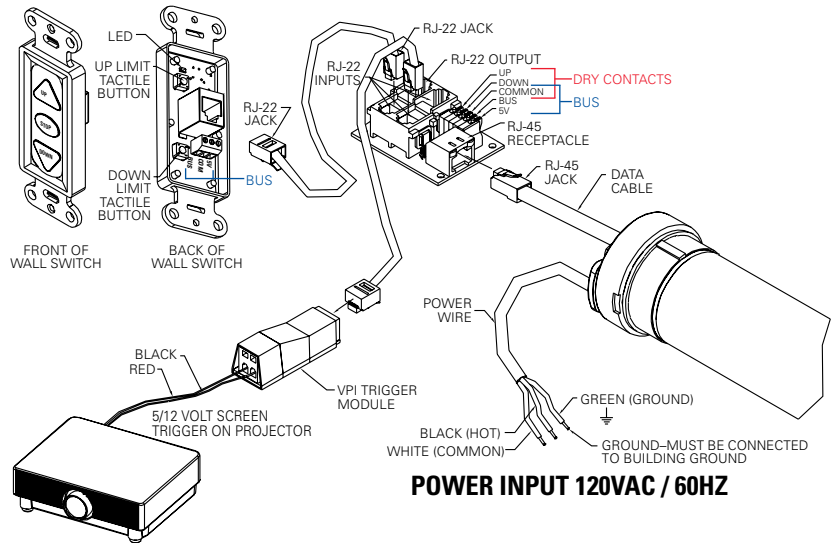

240V WIRING DIAGRAM WITH OPTIONAL BUILT-IN VIDEO PROJECTOR INTERFACE

CAUTION: THE PROJECTOR MUST BE TURNED OFF BEFORE CONNECTING THE TRIGGER WIRES TO THE PROJECTOR. FAILURE TO DO SO MAY DAMAGE THE CONTROLLER.

- Use 2-conductor 20-24 gauge wire to extend the low voltage connection from the projector's 5 or 12-volt screen trigger output to the length required to reach the VPI. When extending the low voltage connection from the projector's screen trigger output, be sure to maintain the proper polarity. The red wire from the VPI is the "signal" and the black wire from the VPI is the "ground".
- Connect the wires from the VPI that are labeled "Low Voltage Connection" to the end of the extended screen trigger wires above.

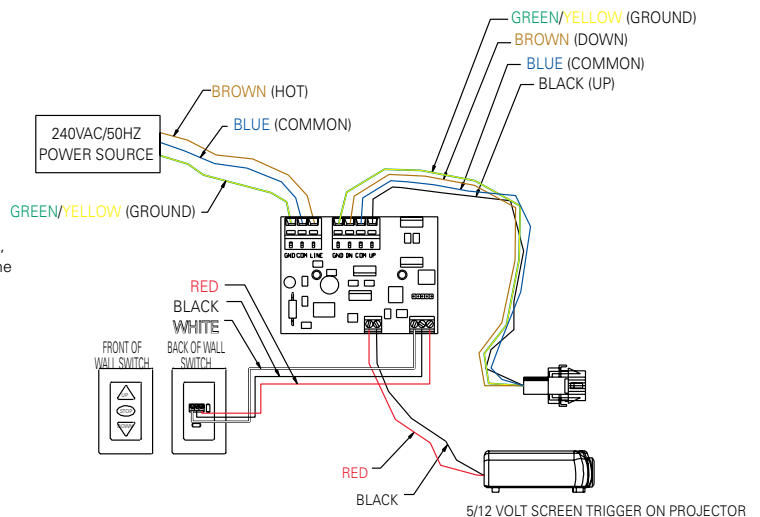

TENSIONED CONTOUR® ELECTROL® INSTALLATION

120V WIRING DIAGRAM WITH OPTIONAL BUILT-IN LOW VOLTAGE CONTROL

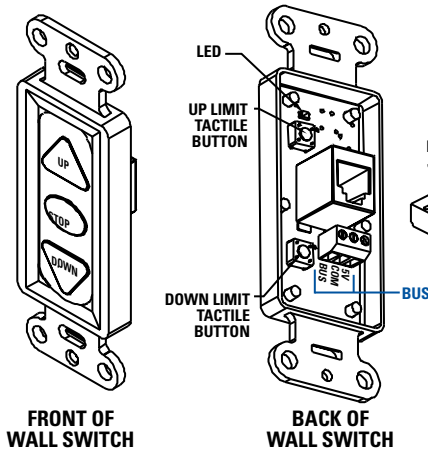

RJ-14 PIN-OUTS (TAB IS FACING UP)

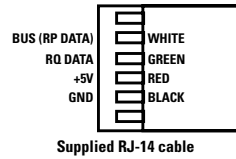

RJ-22 PIN-OUTS (TAB IS FACING UP)

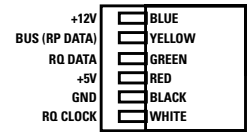

RJ-45 PIN-OUTS (TAB IS FACING UP)

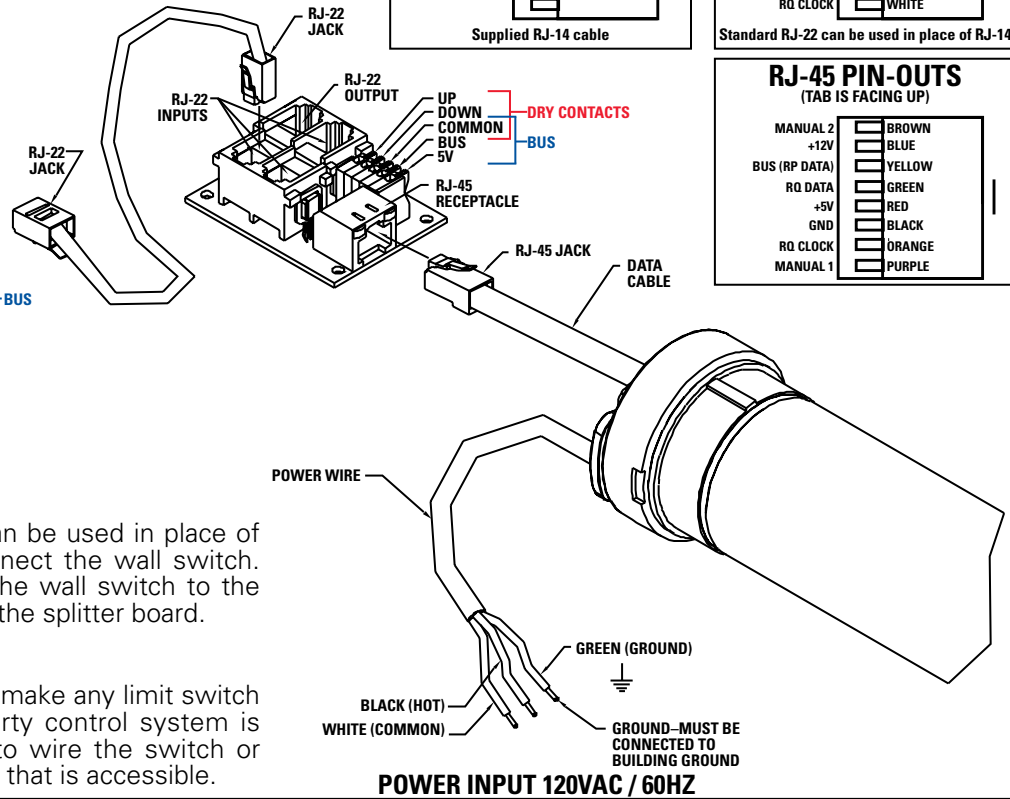
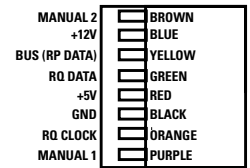

3-conductor 20-24 gauge wire can be used in place of the supplied RJ-14 cable to connect the wall switch. Connect the BUS terminals on the wall switch to the corresponding BUS terminals on the splitter board.

IMPORTANT NOTE:

The wall switch is **REQUIRED** to make any limit switch adjustments, **EVEN** if a third party control system is used. Therefore, it is advised to wire the switch or provide a 3-conductor connection that is accessible.

240V WIRING DIAGRAM WITH OPTIONAL BUILT-IN LOW VOLTAGE CONTROL

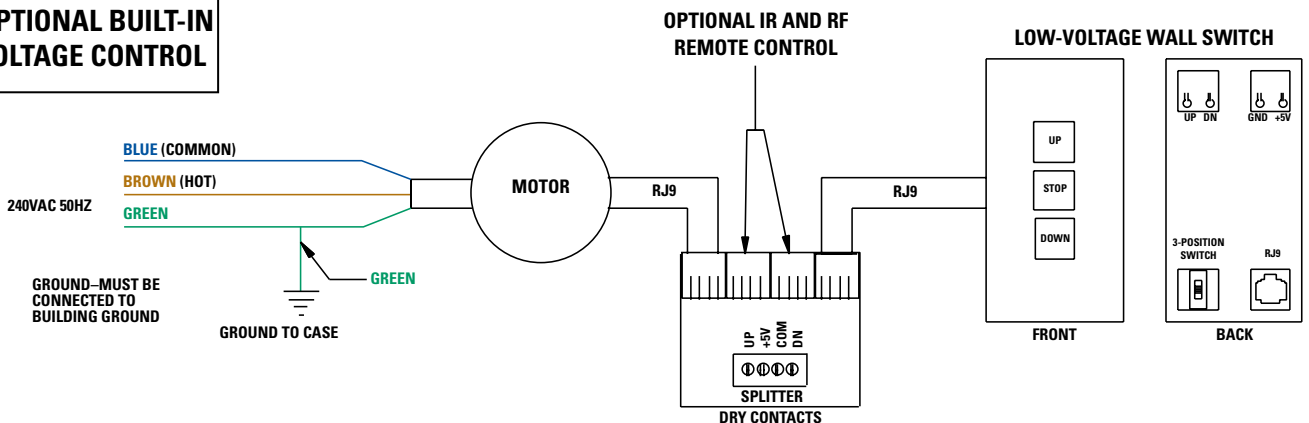

ILT RJ9 PIN-OUTS (TAB IS FACING UP)



IMPORTANT NOTE: The wall switch is **REQUIRED** to make any limit switch adjustments, **EVEN** if a third party control system is used. Therefore, it is advised to wire the switch or provide a 4-conductor connection that is accessible.

TROUBLESHOOTING

Visit www.da-lite.com/products/tutorials.php to find installation and troubleshooting tutorials. You will also find a link to Live Chat for interactive support and you can contact us by email at info@da-lite.com or by phone at (800) 622-3737 or (574) 267-8101 with any troubleshooting questions.

SYMPTOM	CAUSE	SOLUTION
1. Screen will not operate. Motor does not hum.	<p>(a) Incorrect line voltage.</p> <p>(b) Blown fuse.</p> <p>(c) Tripped circuit breaker.</p> <p>(d) No power to operating switch or junction.</p> <p>Power at junction box</p> <p>(e) Thermal overload tripped.</p> <p>(f) Broken wire in the "down" or "up" position.</p> <p>(g) Defective motor, limit switch or capacitor.</p> <p>(h) Capacitor burned out.</p>	<p>(a) Verify 115-125V (or 220-240V). If insufficient voltage, rewire incoming electric line.</p> <p>(b) Replace fuse.</p> <p>(c) Reset circuit breaker.</p> <p>(d) Check above. Tighten all loose wire connections. Correct any improper connections.</p> <p>"Down" Position Check for power across black and white leads.</p> <p>"Up" Position Check for power across red and white leads.</p> <p>(e) Let motor cool down for 15 minutes. Try again.</p> <p>(f) Check for continuity. Cut off old splice and reconnect.</p> <p>(g) Replace motor assembly. NOTE: Motor is a sealed assembly.</p> <p>(h) Replace motor assembly.</p>
2. Incorrect stopping position in downward direction.	(a) "Down" limit switch out of adjustment	(a) Contact Da-Lite at 800-622-3737 or 574-267-8101.
3. Incorrect stopping position in upward direction.	(a) "Up" limit switch out of adjustment	(a) Contact Da-Lite at 800-622-3737 or 574-267-8101.
4. Noise. NOTE: Screen will operate with a low pitched hum.	(a) Gear Noise.	(a) Replace motor assembly.
5. Coasting.	(a) Defective brake.	(a) Replace motor assembly.

**LIMITED ONE YEAR WARRANTY
ON DA-LITE PRESENTATION PRODUCTS**

Da-Lite Screen Company, Inc. warrants its products to the original purchaser only, to be free from defects in materials and workmanship for a period of one (1) year from the date of purchase by the original purchaser provided they are properly operated according to Da-Lite's instructions and are not damaged due to improper handling or treatment after shipment from the factory.

This warranty does not apply to equipment showing evidence of misuse, abuse or accidental damage, or which has been tampered with or repaired by a person other than authorized Da-Lite personnel.

Da-Lite's sole obligation under this warranty shall be to repair or to replace (at Da-Lite's option) the defective part of the merchandise. Returns for service should be made to your Da-Lite dealer. If it is necessary for the dealer to return the screen or part to Da-Lite, transportation expenses to and from Da-Lite are payable by the purchaser and Da-Lite is not responsible for damage in shipment. To protect yourself against damage or loss in transit, insure the product and prepay all transportation expenses.

THIS WARRANTY IS IN LIEU OF ALL OTHER WARRANTIES, EXPRESS OR IMPLIED, INCLUDING WARRANTIES AS TO FITNESS FOR USE AND MERCHANT ABILITY. Any implied warranties of fitness for use, or merchantability, that may be mandated by statute or rule of law are limited to the one (1) year warranty period. This warranty gives you specific legal rights, and you may also have other rights, which vary from state-to-state. **NO LIABILITY IS ASSUMED FOR EXPENSES OR DAMAGES RESULTING FROM INTERRUPTION IN OPERATION OF EQUIPMENT, OR FOR INCIDENTAL, DIRECT, OR CONSEQUENTIAL DAMAGES OF ANY NATURE.**

In the event that there is a defect in materials or workmanship of a Da-Lite product, you may contact our Sales Partners at PO Box 137, Warsaw, IN 46581-0137, (574) 267-8101, (800) 622-3737.

IMPORTANT: THIS WARRANTY SHALL NOT BE VALID AND DA-LITE SHALL NOT BE BOUND BY THIS WARRANTY IF THE PRODUCT IS NOT OPERATED IN ACCORDANCE WITH DA-LITE'S WRITTEN INSTRUCTIONS.

Keep your sales receipt to prove the date of purchase and your original ownership.